

3HS Three Element Stainless Steel Heaters

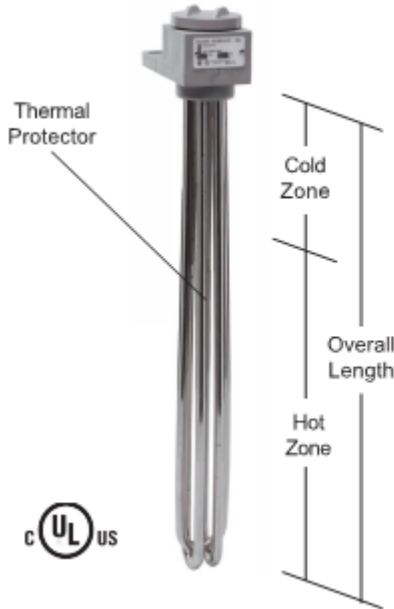

3HS SERIES, THREE ELEMENT STAINLESS STEEL HEATERS					
WATTS	VOLTS	HOT ZONE In./ (mm)	OVERALL LENGTH In./ (mm)	MODEL NUMBER	SHIP WGT. Lbs./ (kg)
3000	240	11	17	3HS3217-**	9
	480	(280)	(430)	3HS3417-**	(4)
4500	240	16	23	3HS4.5223-**	10
	480	(405)	(585)	3HS4.5423-**	(4.5)
7500	240	21	29	3HS7.5229-**	12
	480	(535)	(735)	3HS7.5429-**	(5.5)
10500	240	26	34	3HS10.5234-**	14
	480	(660)	(865)	3HS10.5434-**	(6.5)

Three phase standard, single phase available as option. Add "-1" before thermal protector designator.

Product Features and Benefits:

- ◆ **SUPERIOR CHEMICAL RESISTANCE:** For use in most aqueous alkaline solutions and rinse tanks. Check solution recommendation chart or with your chemical supplier for proper sheath material selection.
- ◆ **RUGGED CONSTRUCTION:** Heavy wall metal sheaths in 316 stainless steel.
- ◆ **OUTSTANDING PERFORMANCE:** Watt densities of 40 watts per square inch (6.2 w/cm²) use minimal space and ensure long service life.
- ◆ **CORROSION RESISTANT HEAD:** Vapor tight, flame retardant polypropylene terminal enclosure with 3-foot (.9m) flexible PVC liquid tight conduit.
- ◆ **SAFETY FEATURES:**
 - Grounded construction.
 - Thermal protector built in. Replaceable P1 fuse standard for solutions up to 180°F (82°C).
 - Non-floating construction.
- ◆ **CERTIFICATIONS:** UL listed to U.S. and Canadian safety standards, and CE.
- ◆ **SIZES:** 3,000 watts to 10,500 watts.
- ◆ **VOLTAGES:** 240 or 480 volts. 208, 380, 415, 600 and other voltages available. Three phase standard, single phase available.
- ◆ **OPTIONS AVAILABLE (consult factory):**
 - Replaceable thermal protectors:
 - P4: for solutions from 180°F (82°C) to 230°F (110°C).
 - Resettable thermal protectors:
 - P2: for solutions up to 180°F (82°C).
 - P6: for solutions from 180°F (82°C) to 230°F (110°C).
 - Special configurations and lengths.
 - Longer wire and conduit lengths.
 - Lower watt densities for highly viscous solutions.
 - Titanium elements.
 - Temperature and level controls sized to match the heater.

3HS Three Element Stainless Steel Heaters

DIMENSIONS

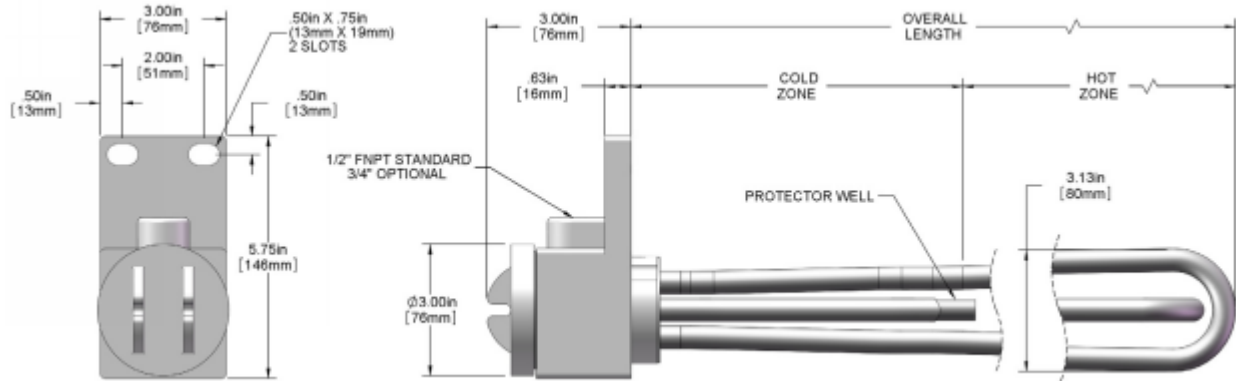

3 ELEMENT OVER THE SIDE HEATER ORDERING INFORMATION

Series	Wattage	Voltage	Overall Length (in.)	Options	Type of Fuse	Wire and Conduit Length														
	3 = 3000 4.5 = 4500 7.5 = 7500 10.5 = 10500	1 = 120 2 = 240 3 = 380 4 = 480 5 = 415 6 = 600 7 = 400 8 = 208 9 = 220 0 = 200	17 = 3kW 23 = 4.5kW 29 = 7.5kW 34 = 10.5kW			36" length standard (no designator) specify variations from standard Ex: -X84 = 84"														
	3HS = 3 element, 316 stainless steel				<table border="1"> <thead> <tr> <th colspan="2">Replaceable Fuse</th> </tr> </thead> <tbody> <tr> <td>-P1 (std)</td> <td>for solutions up to 180°F</td> </tr> <tr> <td>-P4</td> <td>for 180° - 230°F solutions</td> </tr> <tr> <th colspan="2">Resettable Fuse</th> </tr> <tr> <td colspan="2">(additional control components required)</td> </tr> <tr> <td>-P2</td> <td>for solutions up to 180°F</td> </tr> <tr> <td>-P6</td> <td>for 180° - 230°F solutions</td> </tr> </tbody> </table>		Replaceable Fuse		-P1 (std)	for solutions up to 180°F	-P4	for 180° - 230°F solutions	Resettable Fuse		(additional control components required)		-P2	for solutions up to 180°F	-P6	for 180° - 230°F solutions
Replaceable Fuse																				
-P1 (std)	for solutions up to 180°F																			
-P4	for 180° - 230°F solutions																			
Resettable Fuse																				
(additional control components required)																				
-P2	for solutions up to 180°F																			
-P6	for 180° - 230°F solutions																			
	no designator = three phase power (standard) -1 = single phase power				1 inch = 25.4mm															