

3HXOL SERIES, MULTI ELEMENT L-SHAPED FLUOROPOLYMER (PTFE) HEATERS							
WATTS	VOLTS	WIDTH In./(mm)	HOT	STD. VERT.	MAX.	MODEL NUMBER	SHIP WGT. Lbs./(kg)
			ZONE In./(mm)	LENGTH* In./(mm)	COLD ZONE In./(mm)		
3000	240	7	13	18	36	3HXOL3207-13-R*-**	20
	480	(180)	(330)	(460)	(915)	3HXOL3407-13-R*-**	(9.5)
4500	240	9	10	18	35	3HXOL4.5209-10-R*-**	21
	480	(230)	(255)	(460)	(890)	3HXOL4.5409-10-R*-**	(9.5)
6000	240	10	19	18	35	3HXOL6210-19-R*-**	22
	480	(255)	(485)	(460)	(890)	3HXOL6410-19-R*-**	(10)
9000	240	10	23	18	35	3HXOL9210-23-R*-**	36
	480	(255)	(585)	(460)	(890)	3HXOL9410-23-R*-**	(16.5)
12000	240	10	30	18	35	3HXOL12210-30-R*-**	42
	480	(255)	(760)	(460)	(890)	3HXOL12410-30-R*-**	(19.5)
15000	240	10	36	18	31	3HXOL15210-36-R*-**	48
	480	(255)	(915)	(460)	(790)	3HXOL15410-36-R*-**	(22)
18000	240	10	42	18	25	3HXOL18210-42-R*-**	54
	480	(255)	(1070)	(460)	(635)	3HXOL18410-42-R*-**	(24.5)
24000	240	14	40	18	28	6HXOL24214-40-R*-**	58
	480	(355)	(1015)	(460)	(710)	6HXOL24414-40-R*-**	(26.5)
27000	240	14	45	18	30	6HXOL27214-45-R*-**	64
	480	(355)	(1145)	(460)	(760)	6HXOL27414-45-R*-**	(29)

Three phase standard.

Product Features and Benefits:

- ◆ **SUPERIOR CHEMICAL RESISTANCE:** Inert to most aqueous acid, alkaline, anodizing and pickling solutions up to 212°F (100°C).
- ◆ **RUGGED CONSTRUCTION:** Heavy wall fluoropolymer (PTFE) covered stainless steel element reduces permeation and eliminates the need for gas purge systems. Guaranteed 100% pinhole free.
- ◆ **OUTSTANDING PERFORMANCE:** Low watt density design (10 watts/square inch, 1.5w/cm²) for long service life.
- ◆ **EVEN HEATING:** Bottom design for even heating and varying liquid levels.
- ◆ **CORROSION RESISTANT HEAD:** Vapor tight, flame retardant polypropylene terminal enclosure with 3-foot (.9m) flexible PVC liquid tight conduit.
- ◆ **SAFETY FEATURES:**
 - Grounded internal metal element.
 - Thermal protector built in. Replaceable PTL-I fuse standard for solutions up to 190°F (88°C).
 - Non-floating construction.
- ◆ **CERTIFICATIONS:** UL (3-18 kW), and CE.
- ◆ **SIZES:** 3,000 watts to 27,000 watts.
- ◆ **VOLTAGES:** 120, 240 or 480 volts. 208, 380, 415, 600 and other voltages available. Three phase standard, single phase available.
- ◆ **OPTIONS AVAILABLE** (consult factory):
 - Replaceable thermal protectors:
 - PTL-IM: for solutions from 190°F (88°C) to 220°F (104°C).
 - Resettable thermal protectors:
 - PTL-II: bi-metal switch for solutions up to 190°F (88°C).
 - PTL-III: type-J thermocouple for solutions from 190°F (88°C) to 210°F (99°C).
 - PIII: type-J thermocouple for solutions from 210°F (99°C) to 250°F (121°C).
 - Longer vertical lengths (cold zones).
 - Polypropylene guards: recommended for applications up to 180°F (82°C).
 - Fluoropolymer (PTFE) guards: recommended for chromic acid or solutions over 180°F (82°C).
 - Special configurations.
 - Longer wire and conduit lengths.
 - Lower watt densities for highly viscous solutions and technical acids.
 - Temperature and level controls sized to match the heater.
 - Single phase power.

DIMENSIONS (up to 18 kW)

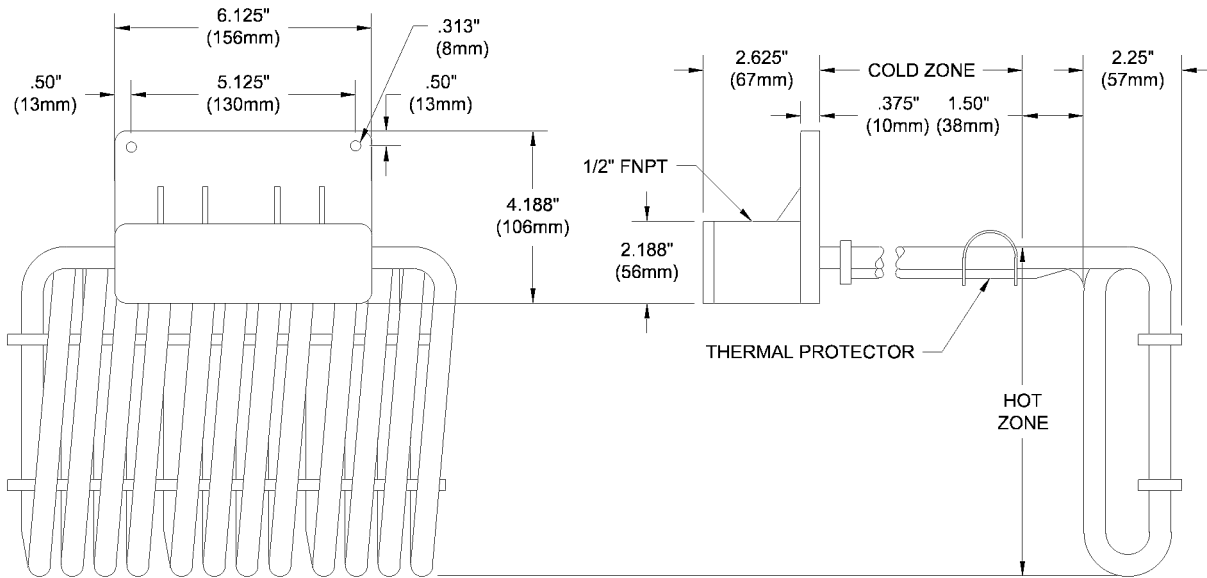

MULTI ELEMENT L-SHAPED FLUOROPOLYMER (PTFE) HEATER

Series	Wattage	Voltage	Width	Options	Horizontal Length	Vertical Length	Guard Option	Type of Fuse	Wire and Conduit Length
	3 = 3000 4.5 = 4500 6 = 6000 9 = 9000 12 = 12000 15 = 15000 18 = 18000 24 = 24000 27 = 27000	1 = 120 2 = 240 4 = 480 -208- = 208 -277- = 277 -380- = 380 -415- = 415 -600- = 600	07 = 3kW 09 = 4kW 10 = 6kW 10 = 9kW 10 = 12kW 10 = 15kW 10 = 18kW 12 = 24kW 12 = 27kW		-13 = 3kW -10 = 4kW -19 = 6kW -23 = 9kW -30 = 12kW -36 = 15kW -42 = 18kW -40 = 24kW -45 = 27kW				no designator = 36" length standard specify variations from standard Ex: -X84 = 84"
					-R18 = 3kW -R18 = 4kW -R18 = 6kW -R18 = 9kW -R18 = 12kW -R18 = 15kW -R18 = 18kW -R18 = 24kW -R18 = 27kW			<p style="text-align: center;">Replaceable Fuse</p> -PTL-I (std) for solutions up to 190°F -PTL-IM for 190° - 220°F solutions <p style="text-align: center;">Resettable Fuse (additional control components required)</p> -PTL-II for solutions up to 190°F -PTL-III for 190° - 210°F solutions -PIII for 210° - 250°F solutions	
	3HXOL = 3 element PTFE sheathed 6HXOL = 6 element PTFE sheathed 3HSOL = 3 element 304 stainless steel 6HSOL = 6 element 304 stainless steel								
	X = any special configuration not called out in the part number (specify in clear text)								
	C = complete with guard no designator = three phase power (standard) -1 = single phase power								

ORDERING EXAMPLE:

3HXOL6210-19-R18-PTL-I-X50

Multi element fluoropolymer L-Shaped heater, 6000 watts, 240 volt, three phase, 10" wide, 19" hot zone, 18" vertical length, PTL-I thermal fuse, 50" wire and conduit

