

HXF SERIES, LOW PROFILE FLUOROPOLYMER (PTFE) HEATERS							
WATTS	VOLTS	HOT	OVERALL	DIA.	MAX.	MODEL	SHIP
		ZONE	LENGTH		COLD ZONE		
		ln./(mm)	ln./(mm)	ln./(mm)	ln./(mm)	NUMBER	Lbs./(kg)
500	120	6	14	5	36	HXF.5105-14-**	6
	240	(155)	(355)	(125)	(915)	HXF.5205-14-**	(2.5)
1000	120	7	14	6	36	HXF1106-14-**	7
	240	(180)	(355)	(155)	(915)	HXF1206-14-**	(3.5)
2000	120	9	17	8	35	HXF2108-17-**	8
	240	(230)	(430)	(205)	(890)	HXF2208-17-**	(4)
	480					HXF2408-17-**	
3000	240	10	23	9	35	HXF3209-23-**	13
	480	(255)	(585)	(230)	(890)	HXF3409-23-**	(6)
4000	240	12	29	11	35	HXF4211-29-**	15
	480	(305)	(735)	(280)	(890)	HXF4411-29-**	(7)
5000	240	13	35	12	31	HXF5212-35-**	18
	480	(330)	(890)	(305)	(790)	HXF5412-35-**	(8)
6000	240	14	40	13	25	HXF6213-40-**	22
	480	(355)	(1015)	(330)	(635)	HXF6413-40-**	(10)

Single phase only. This configuration is not recommended for electroless chemistry or phosphoric acid.

Product Features and Benefits:

- ◆ **SUPERIOR CHEMICAL RESISTANCE:** Inert to most aqueous acid, alkaline, anodizing and pickling solutions up to 212°F (100°C).
- ◆ **RUGGED CONSTRUCTION:** Heavy wall fluoropolymer (PTFE) covered stainless steel element reduces permeation and eliminates the need for gas purge systems. Guaranteed 100% pinhole free.
- ◆ **OUTSTANDING PERFORMANCE:** Low watt density design (10 watts/square inch, 1.5w/cm²) for long service life. Flat, low profile design saves space in the tank. (This configuration not recommended for electroless chemistries or phosphoric acid).
- ◆ **CORROSION RESISTANT HEAD:** Vapor tight, flame retardant polypropylene terminal enclosure with 3-foot (.9m) flexible PVC liquid tight conduit.
- ◆ **SAFETY FEATURES:**
 - Grounded internal metal element.
 - Thermal protector built in. Replaceable PT-I fuse standard for solutions up to 190°F (88°C).
 - Non-floating construction.
- ◆ **CERTIFICATIONS:** UL, CSA, and CE.
- ◆ **SIZES:** 500 watts to 6,000 watts.
- ◆ **VOLTAGES:** 120, 240 or 480 volts. 208, 380, 415, 600 and other voltages available. Single phase only.
- ◆ **OPTIONS AVAILABLE** (consult factory):
 - Replaceable thermal protectors:
 - PT-IM: for solutions from 190°F (88°C) to 220°F (104°C).
 - Resettable thermal protectors:
 - PT-II: bi-metal switch for solutions up to 190°F (88°C).
 - PT-III: type-J thermocouple for solutions from 190°F (88°C) to 210°F (99°C).
 - PIII: type-J thermocouple for solutions from 210°F (99°C) to 250°F (121°C).
 - Longer vertical lengths (cold zones).
 - Polypropylene guards: recommended for applications up to 180°F (82°C).
 - Fluoropolymer (PTFE) guards: recommended for chromic acid or solutions over 180°F (82°C).
 - Special configurations.
 - Longer wire and conduit lengths.
 - Flexible continuous fluoropolymer leads (PIII protector only).
 - Lower watt densities for highly viscous solutions and technical acids.
 - Temperature and level controls sized to match the heater.

www.oemheaters.com

Toll Free: (866) 685-4443

Email: info@oemheaters.com

DIMENSIONS

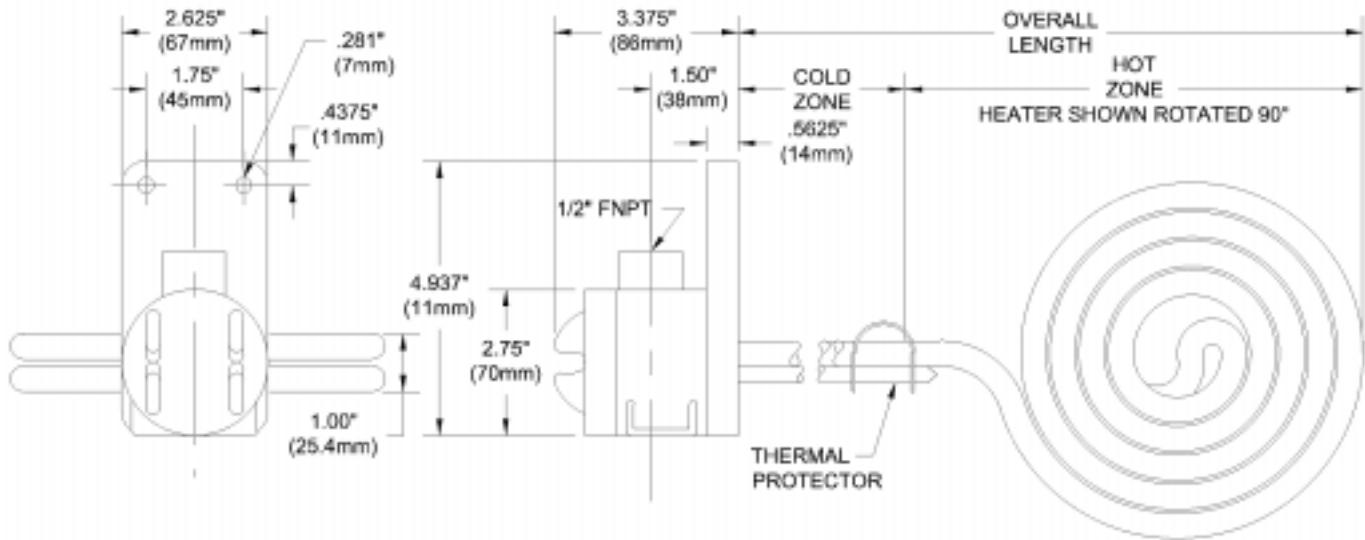

LOW PROFILE FLUOROPOLYMER (PTFE) HEATER

Series	Wattage	Voltage	Diameter	Overall Length	Options	Type of Fuse	Wire and Conduit Length
	.5 = 500 1 = 1000 2 = 2000 3 = 3000 4 = 4000 5 = 5000 6 = 6000	1 = 120 2 = 240 4 = 480 -208- = 208 -277- = 277 -380- = 380 -415- = 415 -600- = 600	05 = .5kW 06 = 1kW 08 = 2W 09 = 3kW 11 = 4kW 12 = 5kW 13 = 6kW	-14 = .5kW -14 = 1kW -17 = 2kW -23 = 3kW -29 = 4kW -35 = 5kW -40 = 6kW specify custom lengths, not to exceed tank depth			no designator = 36" length standard specify variations from standard Ex: -X84 = 84"
	HXF = PTFE sheathed HSF = 304 stainless steel					Replaceable Fuse	
						-PT-I (std)	for solutions up to 190°F
						-PT-IM	for 190° - 220°F solutions
						Resettable Fuse	
						(additional control components required)	
						-PT-II	for solutions up to 190°F
						-PT-III	for 190° - 210°F solutions
						-PIII	for 210° - 250°F solutions
X = any special configuration not called out in the part number (specify in clear text) C = complete with guard							

ORDERING EXAMPLE:

HXF5412-35-PT-I-X50

Flat fluoropolymer heater, 5000 watts, 480 volt, single phase, 12" diameter hot zone, 35" overall length, PT-I thermal fuse, 50" wire and conduit

O.E.M. HEATERS

www.oemheaters.com

Toll Free: (866) 685-4443

Email: info@oemheaters.com